

ULTRA ZONE HUMIDIFIERS

This service bulletin describes the steps that may be necessary to replace your existing Model ESU14 or ESU20 Steam Humidifier, with the new Model S2000 or S2020 Power Steam Humidifier. The new “S” models have been redesigned and improved. There are some differences which must be taken into account when installing this unit or replacing an older model.

1. MOUNTING - First and most important is the mounting of the new humidifier. The new model has a larger reservoir but measures the same width and height as the old “ESU”. The reservoir protrudes deeper into the duct and occupies more space inside the duct. The new “Under Duct Mounting Flange” is an integral part of the reservoir. As a result, the modification to perform when mounting the new S2000 or S2020, is to snip and lengthen the flange dimension on your existing reservoir cutout opening in the warm air supply plenum.

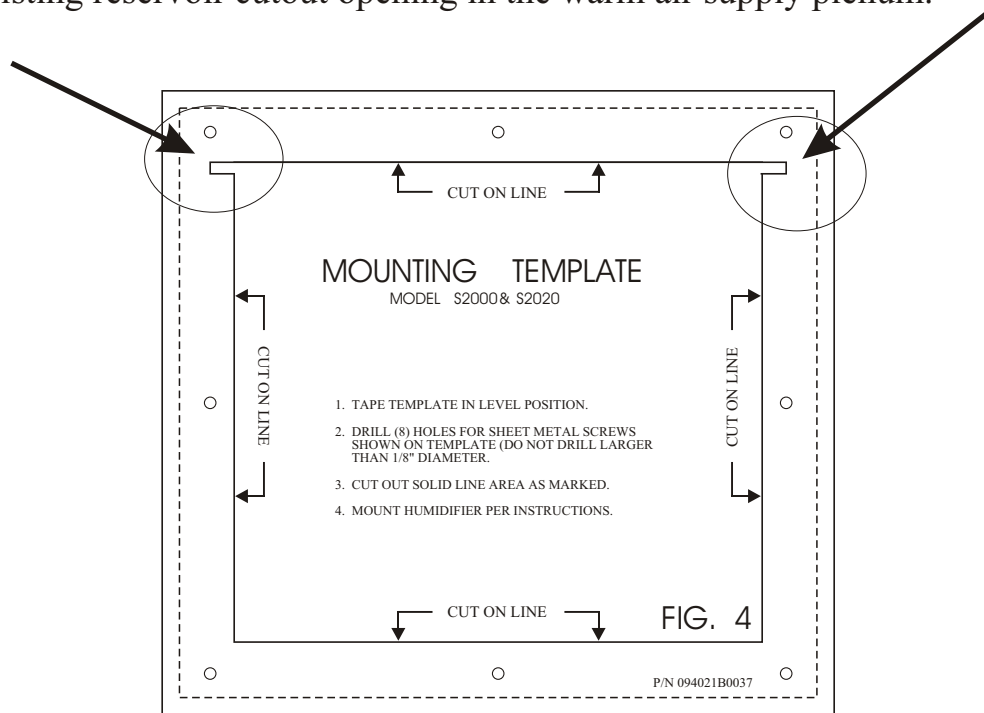

With this modification done, you should be able to insert the new humidifier into the cutout opening and secure the unit with the 8 self tapping screws provided. The hole dimensions on the front plate have not changed and should match up. If necessary, locally reinforce the opening with sheet metal sleeves to insure that the unit will remain level and not sag with the added weight of the water.

A 2nd template is included with the “S” series humidifiers for mounting the unit under the duct on the return or cold air side of the furnace. Note that there is no need to order an under the duct mounting kit, due to the new integrated mounting flange.

ULTRA ZONE HUMIDIFIERS

2. WIRING - Another important difference in the replacement of an “ESU” model with a new “S” series humidifier is the wiring connections. On the “ESU” the humidity control was connected to the two ‘WHITE’ wires on the molded plug. When upgrading to the “S” series, simply cut the two white wires and connect them to the two “H” terminals on the top of the front cover.

The blower (fan) interlock was connected via the two red wires on the old “ESU” model and usually incorporated a field installed transformer and interlocking relay. Just cut the two red wires and connect them to the “R” and “G2” terminals on the top of the front cover. In this method you can reuse the field relay and transformer which were originally installed with the ESU.

If this is a new install then you can fully utilize the on board relay provided with the “S” series humidifier and interlock your blower “fan” by following the low voltage diagram. There is no need to install a separate transformer or relay.

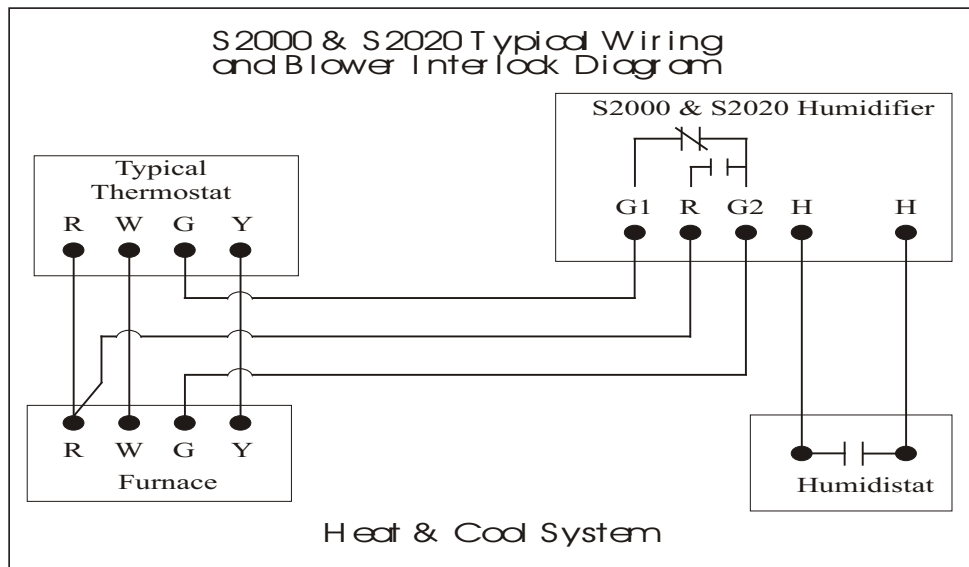

DO NOT plug the molex connector from the old “ESU” humidifier, into the socket on the side of the front cover on the new “S” series humidifier. That socket connection is now reserved for the automatic drain valve only. Doing so will damage the unit and void the warranty.



APPLICATION NOTE

AN-137 Replacement Instructions for ULTRA-ZONE Models ESU14 & ESU20

*SUPPLEMENT TO THE ULTRA-ZONE ELECTRONIC STEAM
POWER HUMIDIFIERS MODEL #S2000 AND S2020*

ULTRA ZONE HUMIDIFIERS

3. DRAINS - It is still necessary to run an overflow drain line from the humidifier to a suitable drain. Now, it is also required to run an additional drain line from the new automatic drain valve to a suitable drain.

The new “S” series humidifiers have an automatic drain valve which will drain the tank every 12 hours, to minimize chemical buildup inside the tank. The water is allowed to cool down to 140 degrees F. before the water is drained out.

The humidifier drains by gravity only, so it must be mounted at a sufficient height to allow for proper drainage. DO NOT route the drain hoses above the level of the humidifier, and watch for kinks or cuts in the hoses.

If you have a basement installation and require draining into a condensate pump, we recommend a Beckett Model # CU451ULHT or CU551ULHT. These pumps are rated for high temperature water and have built in check valves.

4. WATER - The frequency which the water fill solenoid on the new steam unit will activate can exceed the older model. This more frequent filling of the tank may be noticeable in the form of water hammer noise or spikes in the water line. Install an optional water hammer arrester #WH-100, and the noise will dissipate.

If this Engineering notice does not cover a question or issue that you have encountered during your installation or replacement project, please contact the Technical Support Hotline @ 1-800-446-3110.