

STEP 1

LEAVE TOP AND
BOTTOM BOARDS
COMPLETE

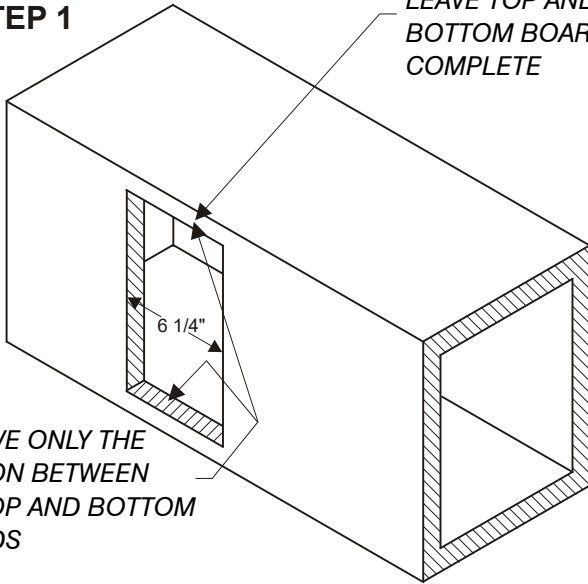

REMOVE ONLY THE
SECTION BETWEEN
THE TOP AND BOTTOM
BOARDS

Each kit should contain two identical side brackets. Remove a section of the duct 6 1/4" wide. Cut between the top and bottom boards being sure to leave them in place, including their edge.

STEP 2

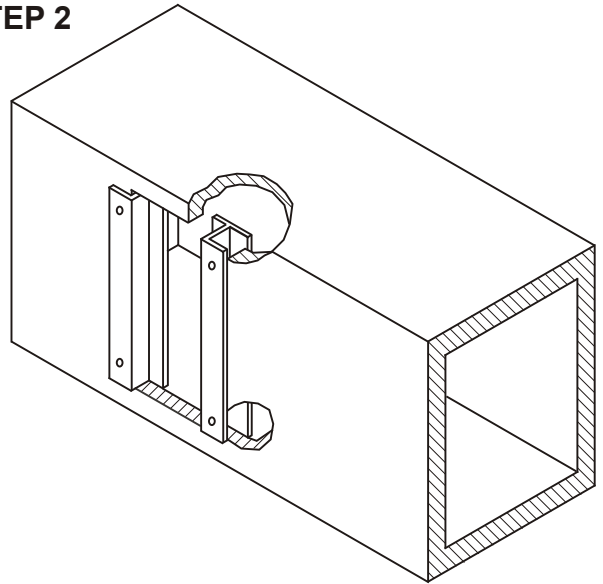

Slide the side brackets over the duct board as shown. Be sure the bracket is positioned so the flanges with the holes are towards the inside of the duct. Be sure to screw the adaptors to the duct with 1 1/2 " or 2" screws.

STEP 3

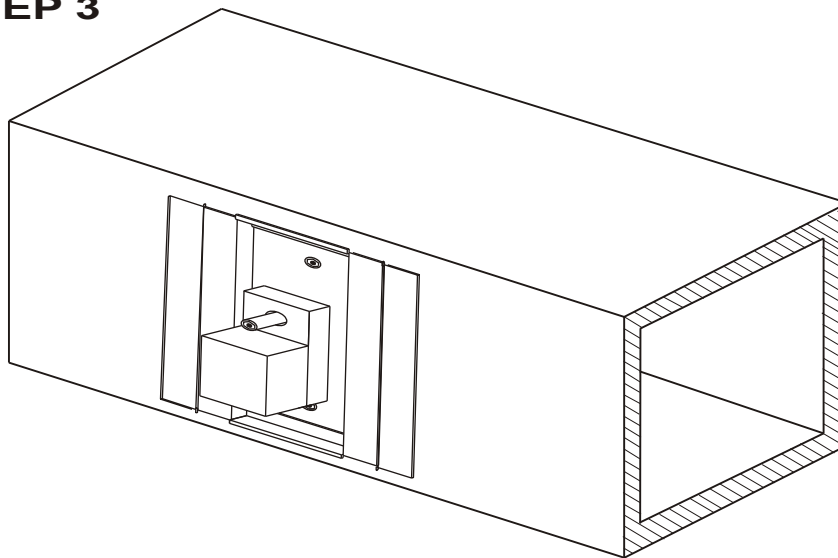

Insert the damper and put in the four corner screws. To secure the damper to the duct board.

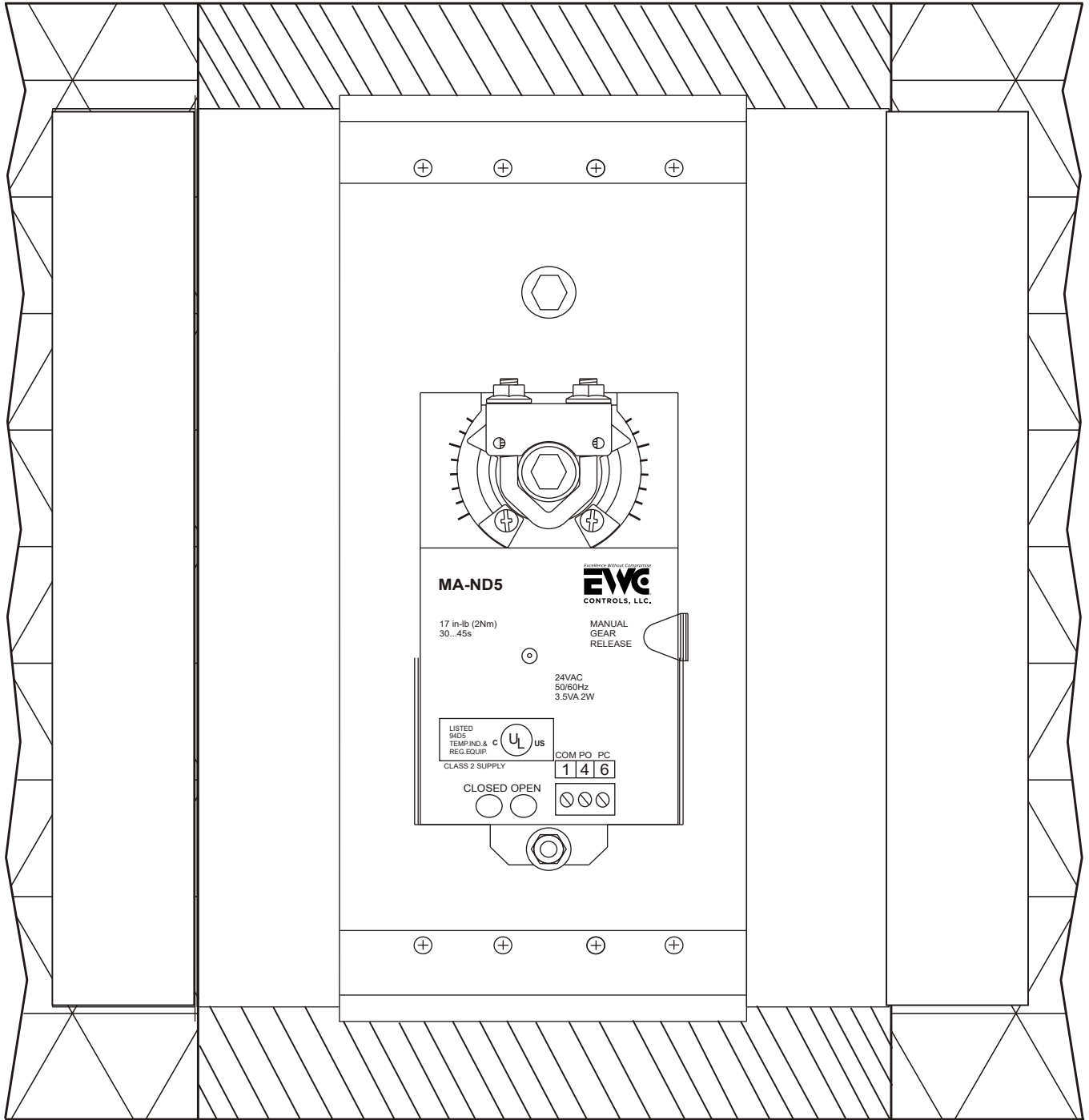

COMPLETED INSTALLATION