

# ULTRA-ZONE<sup>®</sup>

Forced Air Zone Controls

## SUBMITTAL SHEET

Model URD Round Damper  
with MA-ND5 Actuator

The URD series of round motorized dampers are a double layered blade design with an integrated cellular foam sealing gasket. The superior design insures long life and no maintenance. URD dampers are easy to install, easy to wire up, and come with a 5 year warranty. The URD damper is constructed of heavy gauge galvanized steel. The nylon bearings and drive shafts insure smooth, quiet operation and provides a thermal barrier to the motor. The URD is designed to operate at static pressures up to 1" w.c. @ < 3% leakage. The UL Listed MA-ND5 Actuator is a 24vac 3 wire power open / power close type rated at 18 " lbs. of torque. It includes an integrated terminal block, and NEMA1 rated housing. The MA-ND5 motor features bright Green and Red LED's which correspond to the OPEN and CLOSED position of the blade. The motor also includes End-Stops for Min/Max position capability to allow adjustment of the design CFM flow into a particular zone or area. The Position LED's will illuminate regardless of the End Stop positions.

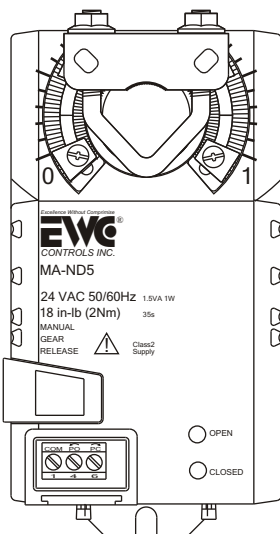
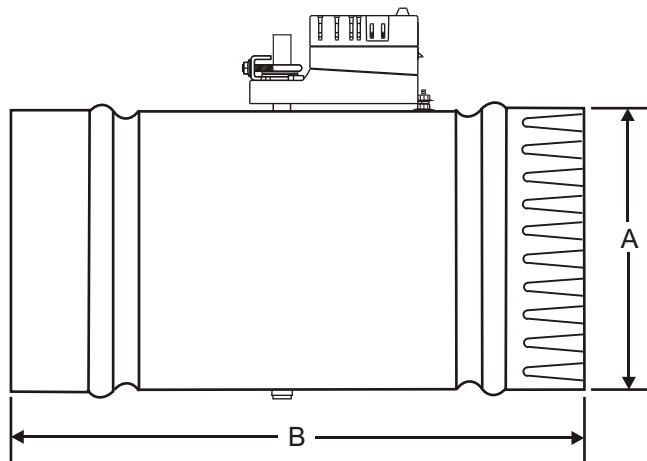

### NOMINAL DIMENSIONS

MODEL #	A	B
URD - 4	4.00"	10.00"
URD - 5	5.00"	10.00"
URD - 6	6.00"	12.00"
URD - 7	7.00"	12.00"
URD - 8	8.00"	12.00"
URD - 9	9.00"	12.00"
URD - 10	10.00"	12.00"
URD - 12	12.00"	14.00"
URD - 14	14.00"	16.00"
URD - 16	16.00"	20.00"
URD - 18	18.00"	20.00"
URD - 20	20.00"	20.00"

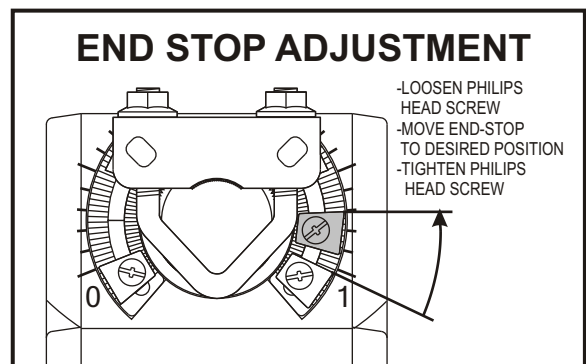

### SUBMITTAL FORM

SUBMITTED BY: \_\_\_\_\_  
 JOB: \_\_\_\_\_  
 ARCHITECT: \_\_\_\_\_  
 ENGINEER: \_\_\_\_\_  
 CONTRACTOR: \_\_\_\_\_  
 LOCATION: \_\_\_\_\_



385 Hwy. 33  
 Englishtown, NJ 07726  
 Ph: 800-446-3110  
 Fx: 732-446-5362

### WIRING SOLUTIONS

#### Motor Actuator Terminals

TERMINAL	DESCRIPTION
1 / COM	24v Common
4 / PO	24v Power to Open
6 / PC	24v Power to Close

#### Wiring to a Zone Control Panel

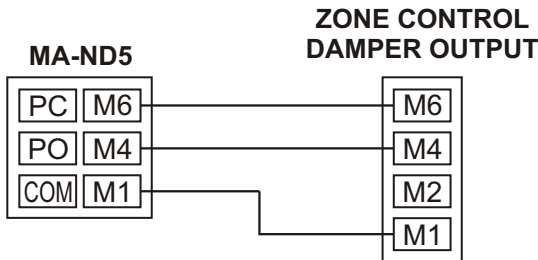

#### Wiring a Thermostat to Control a Single Damper

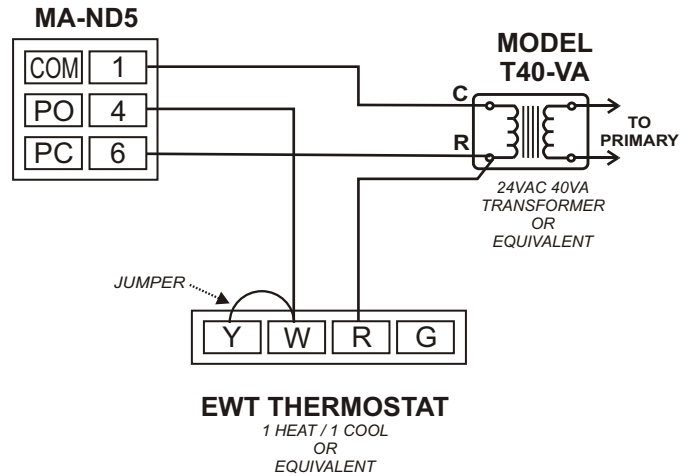

#### Wiring in Parallel

