

The model UDB is an optional installation accessory for the S2000 and S2020 Steam Humidifier. The UDB is designed to ease the mounting process and facilitate removal of the humidifier for inspection and maintenance

- 1) Apply gasket around perimeter of bracket (see illustration).
- 2) Find a suitable location to install the humidifier in the supply or return plenum.
- 3) Place the template on the bottom of the duct in the location the humidifier is to be installed
Make sure no other internal components exist in that location that may be damaged. i.e. Evaporator Coil, UV Lamp, etc..
- 4) Line the front edge of the template with the corner of the duct and tape in place.
- 5) Drill 8 holes shown on the template using an 1/8" drill bit (DO NOT DRILL LARGER THAN 1/8" DIAMETER)
- 6) Cut out the solid line area as marked on the template.
- 7) Remove the template from the duct.
- 8) Line up holes in the duct bottom with holes on the bracket.
- 9) Fasten the bracket to the duct bottom using the provided sheet metal screws.
- 10) With the bracket secure, using the holes on the front flange of the bracket as a guide, drill 5 pilot holes into the duct side.
- 11) Fasten the top left and top right corners of the front flange to the duct using the provided sheet metal screws.
- 12) Slide the humidifier into the bracket and secure Humidifier with 3 remaining screws.
- 13) Refer to S2020/S2000 Steam Humidifier installation instructions to continue with the installation.

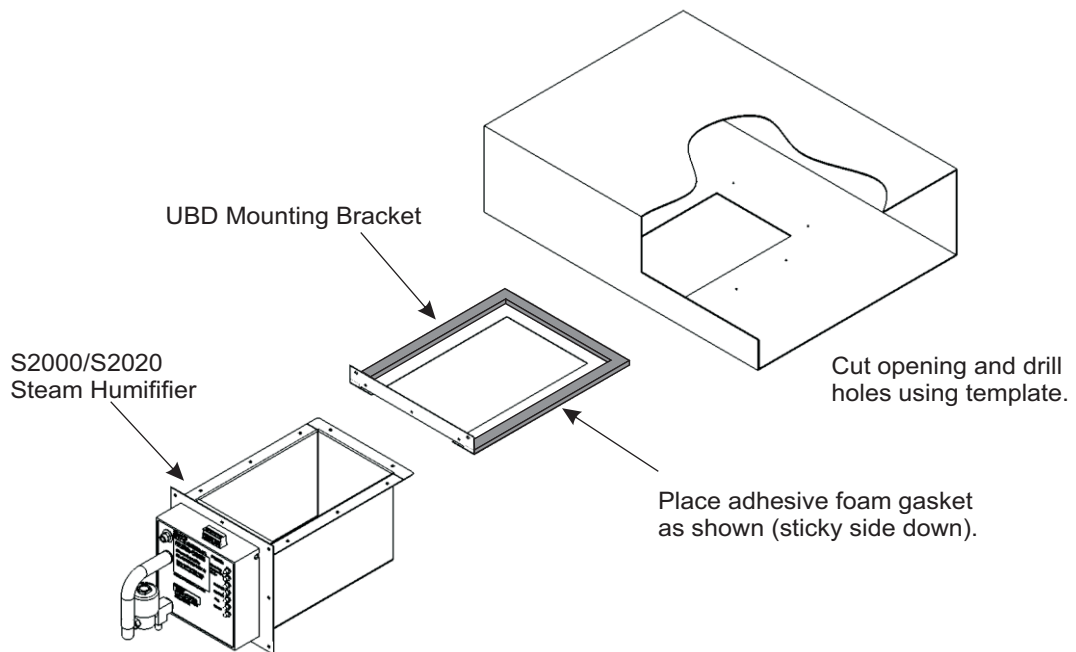

SUBMITTAL FORM

SUBMITTED BY: _____
 JOB: _____
 ARCHITECT: _____
 ENGINEER: _____
 CONTRACTOR: _____
 LOCATION: _____

Excellence Without Compromise

EWC®
 CONTROLS INC.

385 Hwy. 33
 Englishtown, NJ 07726
 Ph: 800-446-3110
 Fx: 732-446-5362

P/N 090377A0142 REV. B